

Palletized vertical machining centres

TANDEM





An innovative project for maximum efficiency in production.

- The new TANDEM machining centres, available in 3-5-6 axes versions, allow "Dual Mode" machining, that is "shuttle mode" and "tandem mode". They are conceived for high productivity in the machining of small and great series in automotive, precision mechanics and mould industries.
- 5-axes version consists of a tilting head (B-axis $\pm 110^\circ$) and a built-in 660 mm diameter rotary table (C-axis). 6-axes version is supplied with a tilting head and two rotary tables sunk into the two worktables.
- Shuttle mode machining allows to mask loading/unloading time, thus assuring a high productivity and efficiency level.

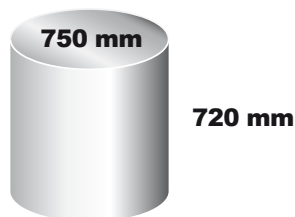

- The same machine can be used with the two pallets joined together, that is in tandem mode, for the machining of big dimensions workpieces, thanks to X-axis traverse that reaches 2,100 mm.
- In few seconds the operator can shift from shuttle mode to tandem mode by means of a single pushbutton on the CNC panel.
- On TANDEM 3A Linear model the two pallets on the X-axis are driven by two very high precision linear motors, thus eliminating any other driving gear. In this way it is possible to obtain high axis dynamics, extreme accuracy and 10 m/s^2 acceleration. Linear motors cooling takes place by the circulation of a temperature controlled fluid.



PRODUCTIVITY, FLEXIBILITY, ACCURACY IN ONE SOLUTION

PRODUCTIVITY

- "Dual Mode" machining in shuttle mode or tandem mode
- Complete workpiece production with one single machine thanks to the use of B and C axes.
- X, Y, Z axes feedrate up to 50 m/min
- X, Y, Z axes acceleration up to 10 m/s²
- Idle time reduction thanks to loading/unloading operations in masked time

VERSATILITY

- Shifting from shuttle mode to tandem mode by means of a single pushbutton on the CNC panel
- Machining of small, medium and big workpieces lots according to the most diversified mix of products

ACCURACY

- Optical scales on linear axes
- Differential temperature control of spindle, tilting head and rotary table by a conditioning circuit
- Compensation of thermal drifts by means of temperature probes connected to the CNC

- The bed of TANDEM machining centres was designed to assure stability and rigidity under any exploitation condition. It is prearranged for the sliding of both movable worktables (X-axis).
- All movements take place on linear slideways with roller recirculation sliding blocks.
- Machine accuracy is assured by absolute pressurized optical scales on X (one reading unit for each table), Y and Z axes and by high resolution encoders on B and C rotating axes.

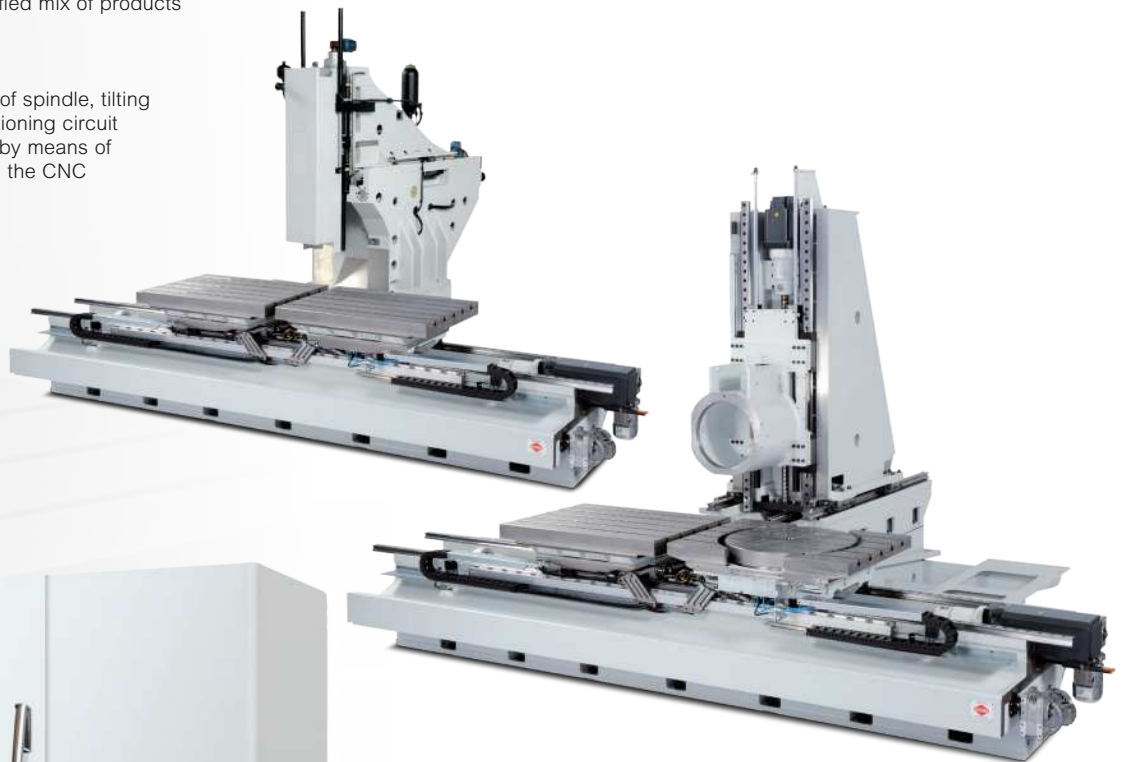

- TANDEM line is equipped with last generation Heidenhain, Siemens e Fanuc CNCs boosting its accuracy and productivity qualities.
- The high ergonomics operator panel is positioned on a sliding front structure.
- New TANDEM machining centres are supplied with new guards conceived according to most innovative industrial design criteria that sum up ergonomics, easy access to the work area, wide visibility during machining, comfort during workpiece loading/unloading operations, optimal fumes and swarf containment, easy use and maintenance.

Palletized vertical machining centres



MOVING TABLE

The configuration with moving worktable on X-axis allows to enhance the accuracy values and final quality of the machined workpieces.



STRUCTURE

The structural concept allows to enhance the rigidity features of the machine in case of extreme exploitation of motorspindle power and torque.



MOTORSPINDLE

Motorspindles are entirely developed and manufactured in SIGMA as a guarantee of reliability and long life, with features of high performances in terms of power (33 kW), torque (180 Nm) and rotation speed (12.000 rpm).



COMPENSATION OF THE THERMAL DRIFTS

Thanks to a system of probes positioned in strategic points of the machine, temperature changes are detected during machining and spindle and linear axes drifts are automatically compensated by the CNC, in order to assure constant accuracy and positioning repeatability.



TILTING MILLING HEAD

Tilting milling heads (B-axis) for simultaneous 4-5 axes machining are developed and manufactured in SIGMA, driven by high performance powerful torque motors to ensure high precision, dynamics, rotation speed and torque.



ROTARY TABLE

Rotary tables (C-axis), embedded in the moving work table, for continuous 5-axis machining with a diameter of 660 mm, are driven by high performance powerful torque motors to ensure high precision, dynamics, rotation speed and torque.

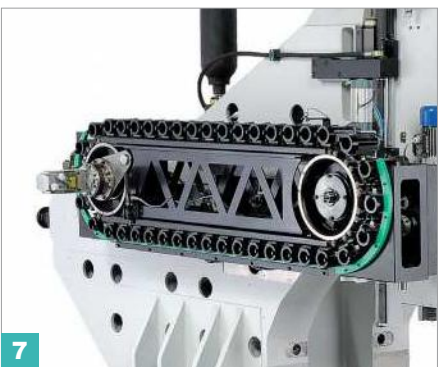

TOOL MAGAZINE

Tool magazines are structurally disconnected from the machine axes movements. This allows for easy inspection and direct replacement of the tools on the tool chain, in total safety, without stopping the working cycle.



SIGMA TOOL CHECK

Electronic device dedicated to all operations related to "direct call" of tools, single tool management (assignment or modification of a tool code, display and modification of tool compensation data) and tool magazine instruction, for direct interface with the CNC, without stopping the working cycle.



DYNAMIC ADJUSTMENT

The dynamic adjustment during milling allows to optimize the dynamic behaviour of the machine in the various working conditions through 5 sophisticated customized CNC functions: standard machining, powerful roughing, accurate finishing, high precision, working speed of the machined workpiece.



SIGMA vertical machining centres and flexible milling cells incorporate excellence in performance deriving from the “**SIGMA DNA**”, a mix of concepts, experiences and exclusive innovations gained and consolidated by SIGMA through its decades of history, which are applied across activities related to product development of all machine models.



10 USER PANEL

The user panel, with a high ergonomic content, developed according to innovative industrial design, is positioned on a sliding front structure.



11 MACHINE GUARDING

Machine guarding is designed according to the most innovative industrial design criteria, by integrating the ergonomic functions such as: easy access to the working area, wide visibility of the operating area, easy loading/unloading of workpieces, containment of fumes and cutting waste, easy maintenance.

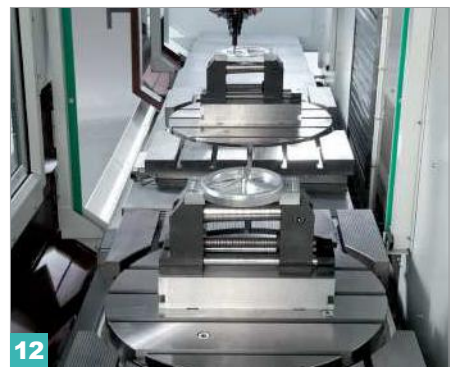

12 AUTOMATION

Process automation is assured by the availability of a palletized system, standard for tandem model (functioning “shuttle mode”) and of modular systems, like cells or flexible manufacturing islands.

Palletized vertical machining centres

Application Markets

The new machining centers TANDEM, in their 3-5-6 versions, have been designed to obtain high productivity in the machining of workpieces, in small and large serial production, in precision mechanics, automotive, moulds and dies fields.



Motorspindles

The standard motorspindle is driven by a synchronous motor, which grants 33 kW power, torque up to 180 Nm and rotation speed up to 12.000 rpm.

A closed-circuit external refrigerator assures the conditioning of the spindle.

As option, two other configurations are available: spindle with 27 kW, 235 Nm and 8.000/15.000 rpm and spindle with 33 kW, 120 Nm and 18.000 rpm.



Power/torque diagram

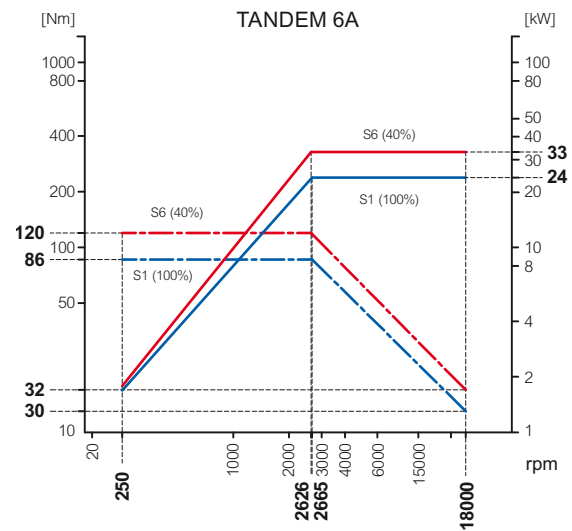
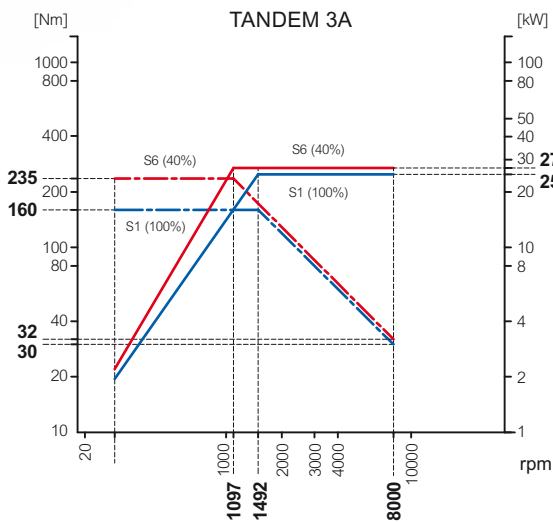

Machine overall dimensions

TANDEM 3A / TANDEM 6A

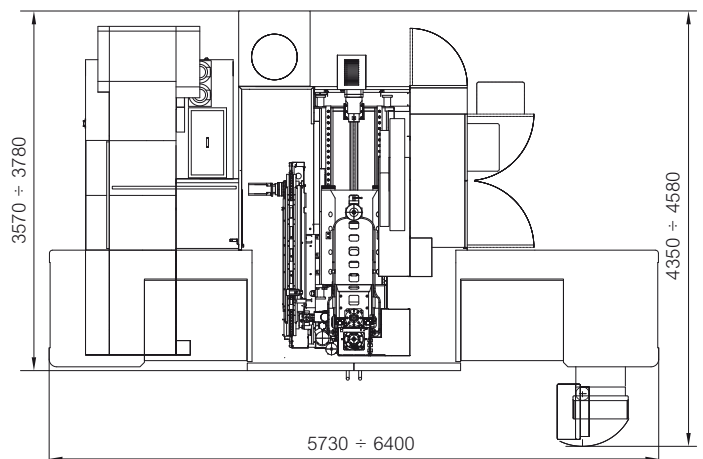
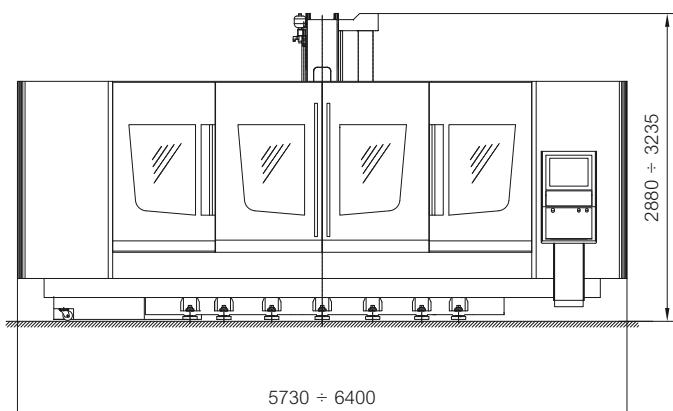

TECHNICAL DATA

WORKING AREA		TANDEM 3A		TANDEM 5A		TANDEM 6A	
X-axis traverse (shuttle mode)	mm inch	2 x 1.000 2 x 39		2 x 1.500 2 x 59		2 x 1.500 2 x 59	
X-axis traverse (tandem mode)	mm inch	2.100 83		2.100 83		2.100 83	
Y-axis traverse	mm inch	810 32		700 28		700 28	
X-axis feedrate	mm inch	630 25		950 37		950 37	
X - Y - Z axes feedrate	m/min ipm	50 - 50 - 50 1969 - 1969 - 1969		40 - 50 - 50 1575 - 1969 - 1969		40 - 50 - 50 1575 - 1969 - 1969	
X - Y - Z axes acceleration	m/s ² ft/s ²	10 - 5 - 5 33 - 16,4 - 16,4		3,5 11,5		3,5 11,5	
Spindle nose - table surface distance	mm inch	150 - 780 6 - 31		840 33		840 33	
Horizontal spindle - table surface distance	mm inch	n.d.		225 - 1.175 9 - 46		225 - 1.175 9 - 46	
Max. workpiece height from table surface	mm inch	n.d.		720 28		720 28	
Linear axes slideways - Axes motion system	type	with recirculation roller sliding blocks - recirculation ball screws					

TABLE							
Table surface (shuttle mode)	mm inch	2 x (770 x 1.000) 2 x (30 x 39)		2 x (730 x 1.000) 2 x (29 x 39)		2 x (730 x 1.000) 2 x (29 x 39)	
Table surface (tandem mode)	mm inch	770 x 2.100 30 x 83		730 x 2.075 29 x 82		730 x 2.075 29 x 82	
Max. load on worktable (shuttle mode)	kg lb	2 x 1.000 2 x 2205		2 x 1.400 2 x 3087		2 x 1.400 2 x 3087	
Max. load on worktable (tandem mode)	kg lb	2.500 5512		2.500 5512		2.500 5512	
Distance between table surface/floor	mm inch	800 31		865 34		865 34	

TILTING HEAD (B AXIS)							
Motor	type	n.d.		torque		torque	
Traverse	degrees	n.d.		± 110		± 110	
Torque (nominal/max./ max. clamping)	Nm lb*ft	n.d.		900 - 1.400 - 3.000 664 - 1033 - 2213		900 - 1.400 - 3.000 664 - 1033 - 2213	
Rapid traverse	rpm	n.d.		60		60	

ROTARY TABLE (C AXIS)							
Motor	type	n.d.		torque		torque	
Traverse	degrees	n.d.		360		360	
Diameter	mm inch	n.d.		660 26		660 26	
Max. load	kg lb	n.d.		1.000 2205		1.000 2205	
Torque (nominal/max./ max. clamping)	Nm lb*ft	n.d.		770 - 1.200 - 3.400 568 - 885 - 2508		770 - 1.200 - 3.400 568 - 885 - 2508	
Rapid traverse	rpm	n.d.		60		60	

LINEAR AXES ACCURACY							
Measuring system X - Y - Z axes	type	absolute pressurized optical scales					
Positioning uncertainty P (VDI/DGQ 3441)	µm	6					

ROTARY AXES ACCURACY B-C							
Positioning / Repeatability	arcsec	n.d.		5" / 4"		5" / 4"	

OTHER DATA							
Weight	kg lb	15.000	33069 approx.	15.000	33069 approx.	16.000	35274 approx.
Floor space: width x depth x height	m ft	5,8 x 4,3 x 3,3 21 x 14 x 11		6,4 x 4,6 x 3,3 19 x 14,8 x 11		6,4 x 4,6 x 3,3 19 x 14,8 x 11	

SPINDLE UNIT							
Spindle speed	rpm	8.000		12.000*		15.000 18.000	
Tool holder taper	type	SK50		SK40* - BT40 HSK-A-63		SK40* - BT40 HSK-A-63 HSK-A-63	
Max. available power S1/S6	kW hp	25/27 34/36		27/33 36/44		25/27 34/36 24/33 32/44	
Max. available torque S1/S6	Nm lb*ft	160/235 118/173		130/180 96/133		160/235 118/173 86/120 74/89	
Constant power from spindle speed S6	rpm	1.100		1.750		1.100 2.630	
Motor	type	motorspindel					
Machine version		3A		5A - 6A		3A 5A - 6A	

TOOL MAGAZINE							
Numero di posti utensili	Nr.	40		48*		60	
Cono di attacco utensili	type	SK50		SK40* - BT40 - HSK-A-63		SK40* - BT40 - HSK-A-63	
Diametro max. utensili adiacenti / a posti alterni	mm inch	125 / 125 5 / 5		76 / 127 3 / 5		76 / 127 3 / 5	
Lunghezza max. utensili	mm inch	300 12		300 12		300 12	
Peso max. utensili	kg lb	18 40		7 15		7 15	
Tempo da truciolo a truciolo	s	7 approx.		5 approx.		5 approx.	
Magazzino	type	bidirectional chain					
Selezione degli utensili	type	random					
Scambiatore utensili	type	double gripper arm					
Accessibilità magazzino	type	independent load/unload station					
Comando locale magazzino	type	"Sigma Tool Check" electronic control panel					

* standard

